

Compact spider hinge, 178° (Maximum opening)

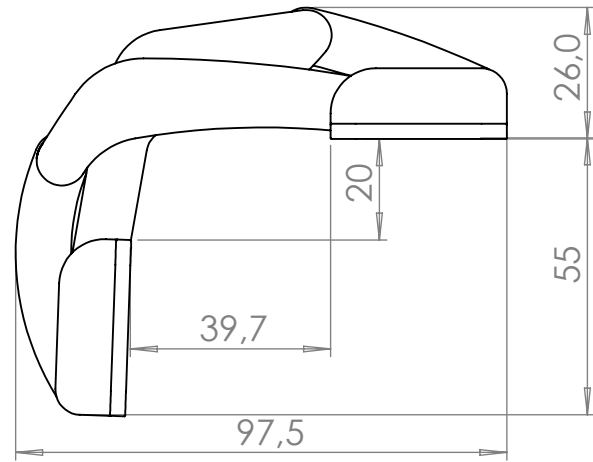

Compact spiderhinge, 0°

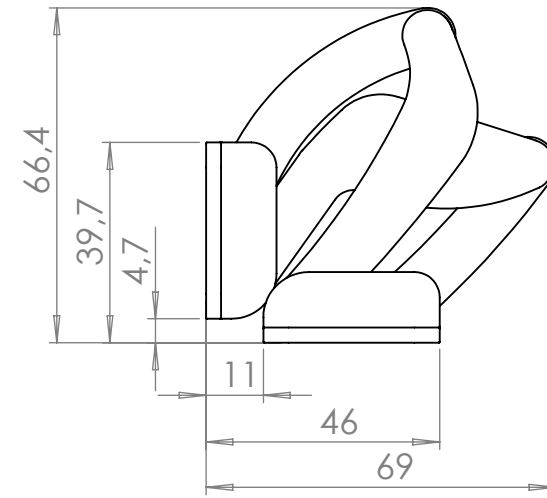

Compact spider hinge, 90° (Top view)

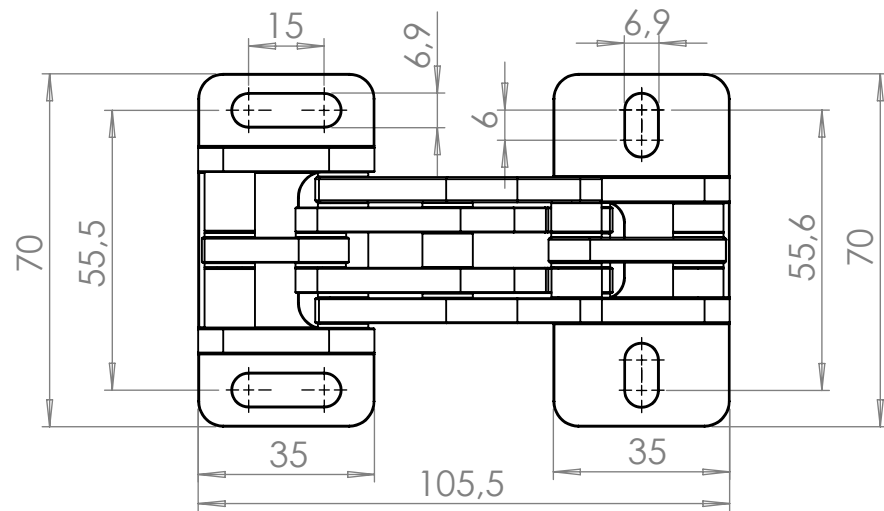

3D FILE YLSCRI		REV. 0																			
MATERIAL AISI 316L	QTY. -	WEIGHT [g] 400	SCALE 2:3																		
SURFACE TREATMENT / FINISHING VEDI SPECIAL NOTES		COD. ARTICOLO HM-Y105	SHEET 1/1																		
 Via San Leo 3 61122 Pesaro (PU) Tel +39 0721 402287 E-mail info@i-carbon.it Web www.i-carbon.it	DATE 19/11/2021	FORMAT A3																			
	COSTUMER -	TOLLERANZE PER MISURE SENZA INDICAZIONI																			
This desing is a private property of YLS srl and can't be reproduced or disclosed without its authorization.		PROJECTION ISO 128	<table border="1"> <tr> <td>da</td> <td>1</td> <td>20</td> <td>100</td> <td>300</td> <td>1°</td> </tr> <tr> <td>a</td> <td>20</td> <td>100</td> <td>300</td> <td>-</td> <td>360°</td> </tr> <tr> <td>±</td> <td>0.02</td> <td>0.05</td> <td>0.1</td> <td>0.3</td> <td>20'</td> </tr> </table>	da	1	20	100	300	1°	a	20	100	300	-	360°	±	0.02	0.05	0.1	0.3	20'
da	1	20	100	300	1°																
a	20	100	300	-	360°																
±	0.02	0.05	0.1	0.3	20'																